

XCell™ ATF 6 Single-use Device

START-UP GUIDE



The information contained in this document is subject to change without notice.

Repligen Corporation makes no warranty of any kind with regard to this material, including, but not limited to, the implied warranties of merchantability and fitness for a particular purpose.

Repligen Corporation shall not be liable for errors contained herein or for incidental or consequential damages in connection with the furnishing, performance, or use of this material.

No part of this document may be photocopied, reproduced, or translated to another language without the prior written consent of Repligen Corporation.

For further information, please contact Repligen Corporation at www.repligen.com.

©2019 Repligen Corporation. All rights reserved. The trademarks mentioned herein are the property of Repligen Corporation and/or its affiliate(s) or their respective owners.

Customer Support

customerserviceUS@repligen.com

+1-781-250-0111 (option 1)

Repligen Corporation

41 Seyon Street Building #1, Suite 100

Waltham, MA 02453

www.repligen.com

Contents

1. About this Start-up Guide	6
2. Intended Use	6
3. General Precautions	6
4. Background	7
5. Product Description and Accessories	7
5.1 Single-use Device	7
5.2 Stainless Steel Stand	8
5.3 Connection Kit (Tubing Sets)	9
6. Prerequisites	9
7. XCell™ ATF 6 Single-use Device Connection Methods	12
8. Filter Wetting Approaches	15
8.1 Background	15
8.2 Offline Wetting	15
8.2.1 Offline Wetting Procedure Instructions	15
8.2.2 Filter Integrity Evaluation	18
8.2.3 Connection to a Bioreactor	19
8.3 Online Wetting	20
8.3.1 Online Wetting Procedure	20
9. Post-use Instructions	23
10. Frequently Asked Questions	24
11. Index	25

List of Tables

Table 6.1	Part Numbers for XCell™ ATF 6 Single Use	11
Table 6.2	Materials of Construction for Product Contact Parts	11
Table 6.3	Materials of Construction for Non-Product Contact Parts	11

List of Figures

Figure 5.1	XCell™ ATF 6 Single-use Device Flow Path and Stainless Steel Stand	8
Figure 5.2	XCell™ ATF 6 Single-use Device Components	9
Figure 6.1	Connection Kit (Tubing Sets)	10
Figure 7.1	Setup an XCell™ ATF 6 Single-use Device with a Single-use Bioreactor (GE ReadyMate)	12
Figure 7.2	Setup an XCell™ ATF 6 Single-use Device with a Single-use Bioreactor (Without GE ReadyMate)	13
Figure 7.3	Setup an XCell™ ATF 6 Single-use Device with a Stainless Steel Bioreactor	14
Figure 8.1	Required Initial Set-Up for the Off-Line Wetting of the XCell™ ATF 6 Single-Use Device	17
Figure 8.2	Required Final Set-Up for the Off-Line Wetting of the XCell™ ATF 6 Single-Use Device	17
Figure 8.3	Required Tubing Clamp Configuration for Disconnecting the Feed and Permeate Wetting Bags from the Device	18
Figure 8.4	Required Tubing Clamp Configuration for Draining the Wetting Solution from the Device Prior to Conducting a Filter Integrity Test	19
Figure 8.5	Required Configuration for Post-Wetting Device Integrity Testing	20
Figure 8.6	Required Initial (Set-Up) Configuration for the Online Wetting of the Device	21
Figure 8.7	Required Working Configuration for Online Wetting of the Device	22
Figure 8.8	Configuration for Disconnecting the Collection Bag from the Device	23

Abbreviations

A2B	XCell™ ATF Device to Bioreactor
A2C	XCell™ ATF Device to Controller
ABS	Acrylonitrile Butadiene Styrene
ATF	Alternating Tangential Flow
DAC	Disposable Aseptic Connector
FIT	Filter Integrity Test
LMH	Liter meter sq. per hour
LPM	Liter per Minute
PES	Polyethersulfone
PMMA	Poly (methyl methacrylate)
PS	Polysulfone
PVDF	Polyvinylidene Fluoride
SCCM	Standard Cubic Centimeter per minute
SS	Stainless Steel
SU	Single-use
SUB	Single-use Bioreactor
WFI	Water for Injection

1. About this Start-up Guide

This Start-Up Guide is for individuals who are planning to use the Repligen XCell™ ATF 6 Single-use Device for cell culture. Although this device is very similar to the XCell™ ATF 6 Stainless Steel Device, this guide provides advice on making the appropriate connections, preparing the device for use, and initiating the cell culture process, all while maintaining sterility throughout the fluid path.

After reading this document, you will be familiar with all system components and you will be able to complete the appropriate connections and configure the system to support the intended process. This guide is not intended to provide guidance on the optimization of the XCell™ ATF 6 Single-use Device operation or to provide guidance on controlling the cell culture process.

2. Intended Use

The XCell™ ATF 6 Single-use Device is intended to be used as a cell retention device to support a high cell density and high viability cell culture operation. The device is designed to enable linear scaling from XCell™ ATF 2 to XCell™ ATF 10 to support multiple scales of cell culture development and cGMP manufacturing. Although it is possible that the use of this device represents an initial step into this type of processing, it is assumed that similar processing with the smaller scale XCell™ ATF 2 or XCell™ ATF 4 systems or the XCell™ ATF 6 stainless steel system has been performed. Therefore, there is a presumption that the individuals following this guide are already skilled in the areas of aseptic technique, process scale fluid handling, interfacing the XCell™ ATF device with the bioreactor and the use of Repligen's XCell™ ATF C410 controller. Additional information on the use of XCell™ ATF systems can be found in the XCell™ ATF System with C24 Controller and XCell™ ATF System with C410 Controller User Guides.

3. General Precautions

The sterile connection between the XCell™ ATF 6 Single-use Device and the bioreactor is made by utilizing GE ReadyMate™ Disposable Aseptic Connectors (DACs). For installation, multiple, varying flow path configurations need to be established by moving tubing clamps along the flow path.

It is important to use sterile technique when making sterile connections. Once the ReadyMate™ connections have been made, the supplied nylon tri-clamp should be installed to secure the aseptic connector assembly. Once the ReadyMate™ connector assembly is secured, there should be no concern for either liquid leakage or a possible introduction of contamination during the process. It is important to ensure the tubing pinch clamps are correctly positioned to establish the required and correct flow path. Operating single-use systems with the pinch clamps requires attention to detail and frequent reassessment of the desired flow paths to ensure that none of the terminating end points are allowed exposure to the atmosphere. Since the pinch clamps can create significant force when crimped, causing the tubing to remain closed when the clamp is released, it is best to inspect the tubing carefully to ensure it is open, and if necessary, to massage or roll the tubing carefully to open it and reestablish flow.

The XCell™ ATF6 Single-use device is supplied pre-sterilized and only requires wetting with sterile cell culture media or WFI prior to use. There is no need to sanitize a device prior to use. The devices

are designed to be single-use and are therefore not designed to be cleaned, sanitized and stored for repeat use. The device should not be exposed to high pH solutions, such as sodium hydroxide for extended time. Repligen advises not to expose the device to even dilute caustic solutions prior to use or for storage. If caustic is used for post use decontamination, the concentration should be limited to 0.1 N and the contact duration limited to one hour.

Note: Refer to the “XCell™ ATF C410 User Guide” for controller related precautions.

4. Background

The XCell™ ATF 6 Single-use Device is a highly efficient cell retention device that features gentle diaphragm pumping action with low shear to avoid shear stress on the cells. This system is utilized in numerous cell culture applications including, but not limited to continuous bioprocessing (perfusion), N-1 perfusion for seed train optimization, high density cell banking and high yield harvest or clarification of fed-batch cultures.

The XCell™ ATF 6 System is also available in the original stainless steel formats. Using the gamma-irradiated/pre-sterilized XCell™ ATF Single-use Device eliminates the need for autoclave procedures, enables faster implementation time, reduces downtime between cell culture runs and reduces validation time and expense.

The XCell™ ATF 6 Single-use Device is supplied dry. It is recommended to pre-wet the device before use to ensure optimal filter performance. This document describes the installation procedure for the XCell™ ATF 6 Single-use Device and tubing sets.

5. Product Description and Accessories

The XCell™ ATF 6 Single-use Device is supplied as a gamma irradiated/pre-sterilized device. The device should be placed in the stainless steel support stand, provided as an accessory, prior to and during use to ensure operational stability. A tubing set with six unique components is also offered to ensure proper and sterile connectivity.

5.1 Single-use Device

The XCell™ ATF 6 Single-use Device components are a diaphragm pump, filter housing, inlet elbow and a hollow fiber filter cartridge fitted within the filter housing. The device contains five ports/connection points: top retentate port, condition/drain port, top permeate port, bottom permeate port and A2C (XCell™ ATF to Controller) port. All ports, except the A2C port, are supplied dead-ended with GE ReadyMate™ DACs. The A2C port, dead-ended with a vent filter, at the lowest point on the pump base is connected to the P-box of the XCell™ C410 controller allowing pressurized air and vacuum to be delivered actuating the diaphragm according to the parameters established by the controller. The other four ports are liquid carrying lines that enable filter cartridge preparation and operation. Two ports are connected to the feed side of the cartridge and the other two ports are connected to the permeate cavity (see Figure 5.1). The top retentate port is used to make a connection between the XCell™ ATF 6 Single-use Device and a bioreactor using A2B1 and A2B2 tubing sets. Typically, the top permeate port is used for harvesting purposes and the lower

permeate port remains closed off throughout the process but could be aseptically connected to a pressure transducer to monitor the permeate pressure during the process.

The hollow fiber cartridge is an integral element within a clear housing. The spherical chamber at the base encompasses the silicone diaphragm which moves up and down as a function of the pressurized air and vacuum flow on the bottom half of the sphere. The clear housing enables the viewing of the diaphragm movement. Figure 5.2 illustrates the components of the XCell™ ATF 6 Single-use Device.

5.2 Stainless Steel Stand

To ensure stability during set-up and use, it is recommended that the device be placed in the stainless steel, reusable stand (see Figure 5.1). The stand features a ring to hold the bottom of the device securely and a snap ring to hold the filter housing near the top of the device. The device snaps into the stand with a single click. After use, the device can be easily removed from the stand. The stand is provided with a notch to orient and secure the A2C line. This feature also helps orient the entire device for efficient connectivity and easy access to all the ports.

Note: The stainless steel stand needs to be ordered separately from the XCell™ ATF 6 Single-use Device.

Figure 5.1 XCell™ ATF 6 Single-use Device Flow Path and Stainless Steel Stand

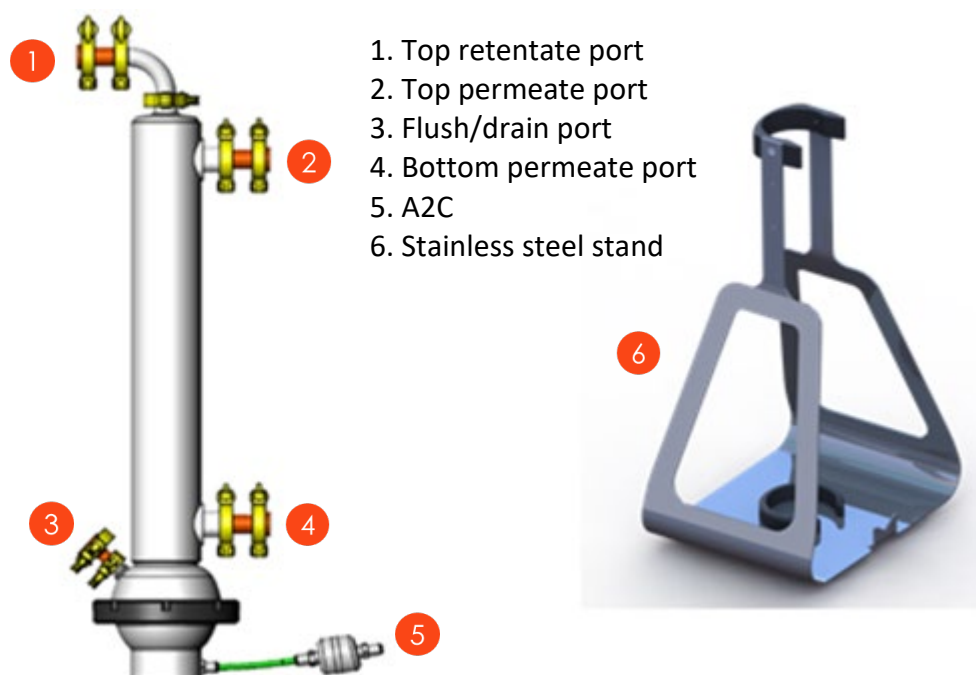
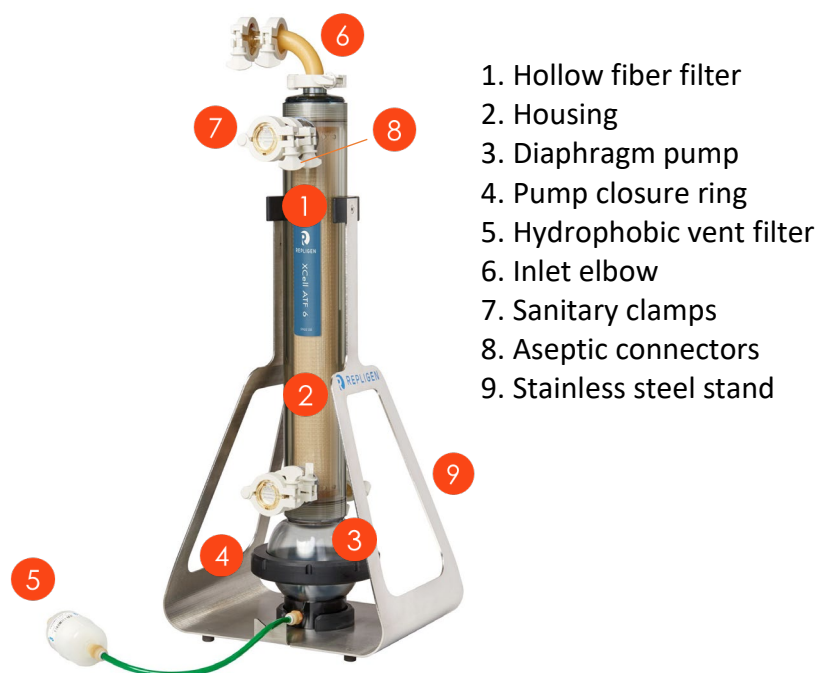

Figure 5.2 XCell™ ATF 6 Single-use Device Components



1. Hollow fiber filter
2. Housing
3. Diaphragm pump
4. Pump closure ring
5. Hydrophobic vent filter
6. Inlet elbow
7. Sanitary clamps
8. Aseptic connectors
9. Stainless steel stand

5.3 Connection Kit (Tubing Sets)

The connection kit contains six individual tubing elements, designed to ensure proper XCell™ ATF 6 Single-use Device functioning. Each tubing element is supplied with the required pinch clamps and sanitary clamps, which are utilized to isolate different fluid paths during the device set-up and to secure the GE ReadyMate™ aseptic connectors respectively. All tubing components, except the A2B2 element, are constructed of silicone and are configured with GE ReadyMate™ connectors and vent filters. The A2B2 element is constructed from C-flex tubing and is configured with GE ReadyMate™ connectors, to make a connection between the XCell™ ATF 6 Single-use Device and a bioreactor by a sterile connector or with tube welding. All tubing sets are sterilized by gamma irradiation and packed in double plastic bags. A description and the intended purpose of each tubing element are noted below in Figure 6.1.

The pinch clamps are used during pre-use filter wetting process and perfusion operations to isolate various fluid paths after use. Note that unlinked GE ReadyMate™ connectors are not water resistant, so in order to maintain systems sterility, extra care must be taken during set-up to not to introduce liquid onto the connector.

Note: The connection kit (tubing set) needs to be ordered separately from the XCell™ ATF 6 Single-use Device.

6. Prerequisites

The following non-supplied equipment is required to operate the XCell™ ATF 6 Single-use Device:

- a. For XCell™ ATF 6 Single-use Operation
 - i. An operational, calibrated XCell™ ATF C410 controller, connected to the required air pressure and vacuum pressure sources
- b. For Permeate (Harvest) Flow

- i. A variable speed peristaltic pump able to support flow rates in the range of 50-400 ml/min depending on the bioreactor working volume and perfusion rate.
 - ii. A minimum length of 1/4th inch ID tubing, fitted with a single ReadyMate™ aseptic connector to mate with the XCell™ ATF 6 Single-use Device. It is recommended that the permeate line be sterilized via gamma irradiation or autoclaving.
- c. For Pre-use, Off-line Filter Wetting
- i. Fifty liters (50L) of 0.2µm filtered WFI or cell culture media dispensed into a Single-use bio container (bag) that is fitted with an appropriate length of tubing, a clamp, and a single, terminal ReadyMate™ aseptic connector.
 - ii. A sterile 50L empty Single-use bio container (bag) with an appropriate length of tubing, a clamp, and a single, terminal ReadyMate™ aseptic connector.
 - iii. A variable speed peristaltic pump with a flow capacity of 1-4 LPM, and able to accommodate the tubing IDs configured on a bag containing 50L media or WFI.

Figure 6.1 Connection Kit (Tubing Sets)

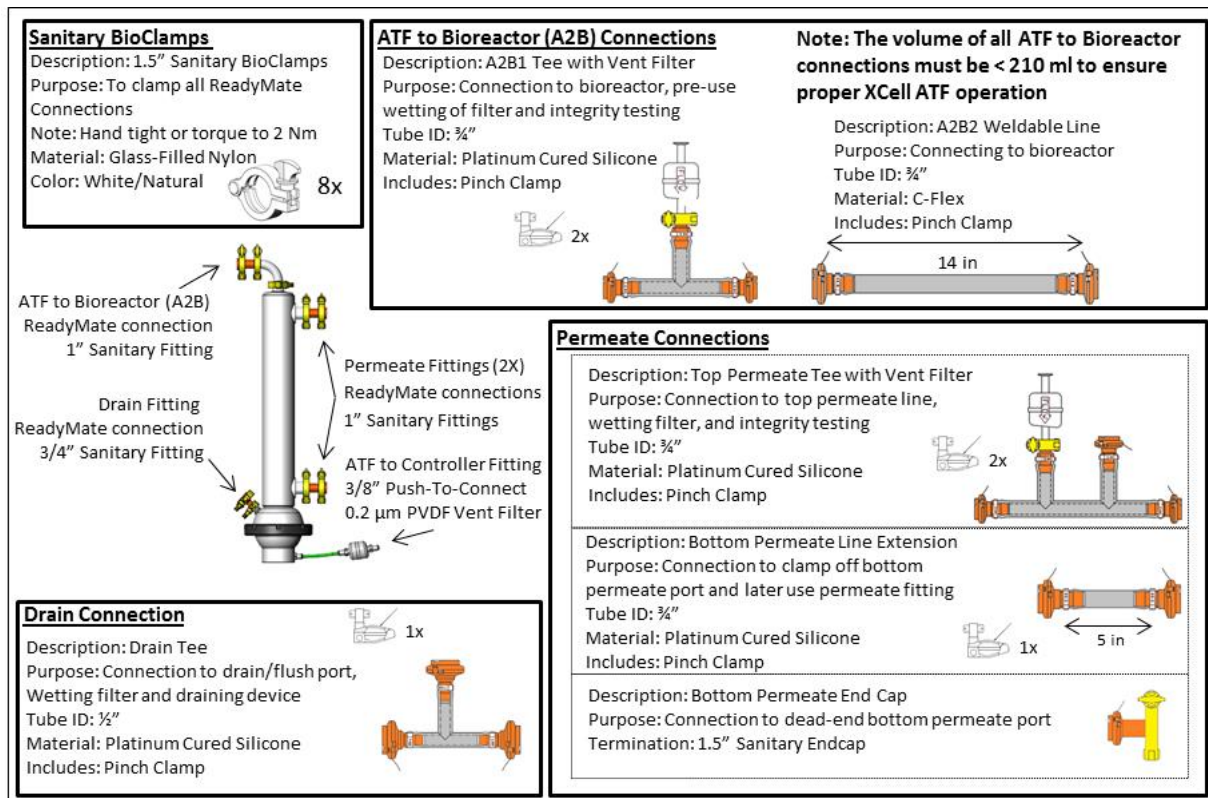

Table 6.1 Part Numbers for XCell™ ATF 6 Single Use

Repligen PN	Description	Notes
suATF6-G02PS	XCell™ ATF 6 Single-use Device, 0.2µm PS	0.2µm filter, GE ReadyMate™ Sanitary Connections
suATF6-S02PES	XCell™ ATF 6 Single-use Device, 0.2µm PES	0.2µm filter, GE ReadyMate™ Sanitary Connections
CS-10359	XCell™ ATF 6 Single-use Stand	Stainless Steel Reusable Stand
suATF6-TubeSetKit	XCell™ ATF 6 Single-use Tubing Set	(6) Individual Tubing elements (see Figure 6.1) (8) Sanitary BioClamps (6) Pinch Clamps

Table 6.2 Materials of Construction for Product Contact Parts

Product Contact Part	Materials of Construction
Filter Housing and Pump	Polycarbonate
Adhesive	Poly(methyl methacrylate) (PMMA)
Tubing	Platinum Cured Silicone & C-Flex (both part of tubing set)
Elbow	Polyvinylidene Fluoride (PVDF)
ReadyMate™ DAC	Polycarbonate with silicone seal
Hollow Fiber Cartridge	PES Membrane - Polyethersulfone, Polysulfone, Polyurethane, and Polypropylene PS Membrane - Polysulfone, Polyethylene, Epoxy, and Polypropylene
Gaskets and Diaphragm	Silicone

Table 6.3 Materials of Construction for Non-Product Contact Parts

Part	Material
Tubing and Sanitary clamps	Glass-Filled Nylon
Pump Closure Ring	Acrylonitrile Butadiene Styrene (ABS)
Stand	ABS, SS

7. XCell™ ATF 6 Single-use Device Connection Methods

The following schematics illustrate the connection methods of XCell™ ATF 6 Single-use Device to stainless steel and single-use bioreactors.

Figure 7.1 Setup an XCell™ ATF 6 Single-use Device with a Single-use Bioreactor (GE ReadyMate)

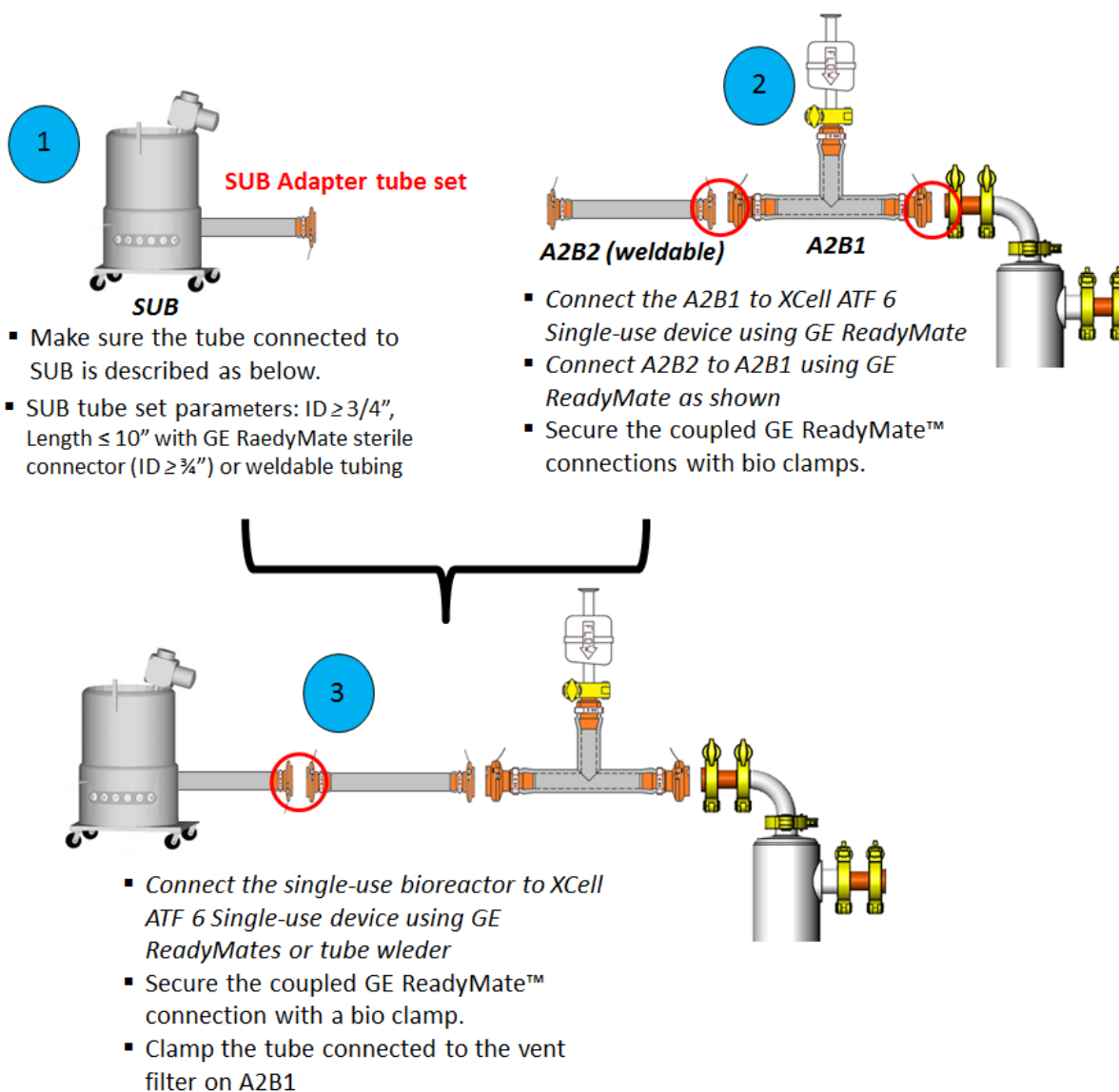

Note: Please refer to Table 6.1 for required part numbers.

Figure 7.2 Setup an XCell™ ATF 6 Single-use Device with a Single-use Bioreactor (Without GE ReadyMate)

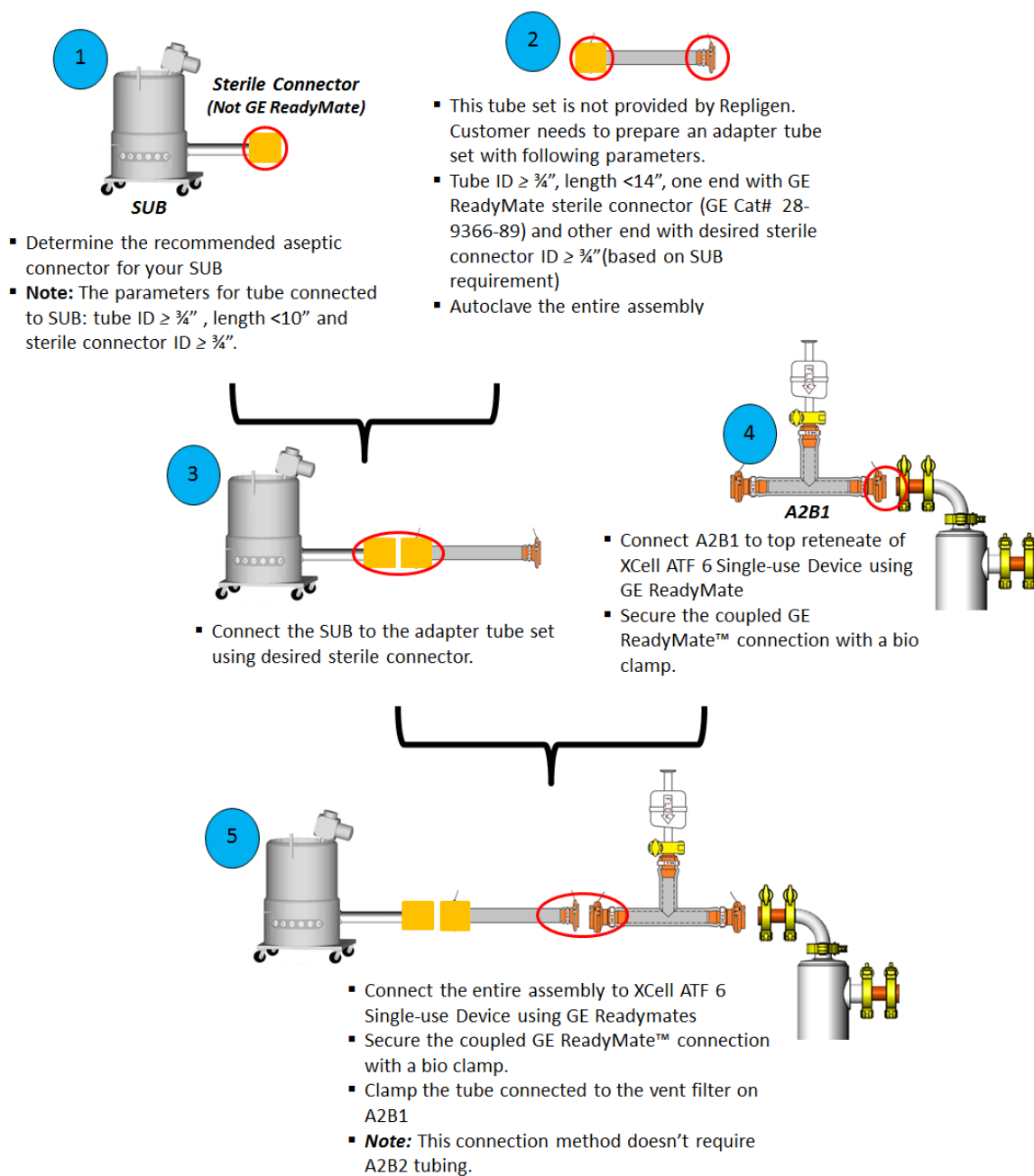
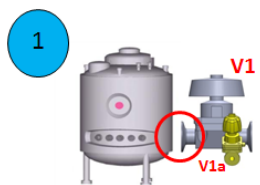
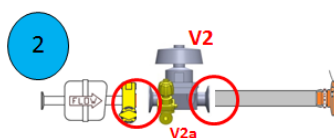

Figure 7.3 Setup an XCell™ ATF 6 Single-use Device with a Stainless Steel Bioreactor



Stainless steel Bioreactor

- Connect a bi-valve (ID $\geq 3/4"$, right facing valve) to the Stainless steel bioreactor
- Attach a trap to opening at V1a valve
- Open V1 and V1a valves
- SIP to sterilize the bioreactor
- Close V1



- This tube set assembly is not provided by Repligen. Customer needs to prepare an adapter tube set by connecting a bi-valve (ID $\geq 3/4"$, left facing valve) and a vent filter on one end and GE ReadyMate on other end, as shown above.
- The length of the tube should be $< 14"$ and ID $\geq 3/4"$.
- Open V2 and V2a valves and autoclave the entire assembly.

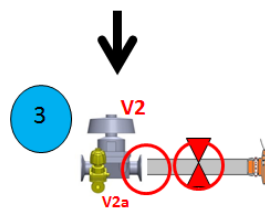

- After sterilization, close V2 valve and remove the vent filter from the assembly.
- Clamp the adapter tube set using tubing clamp as shown

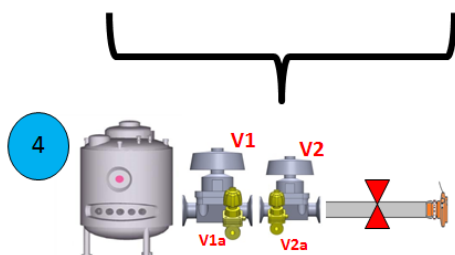

- Attach two bi-valves to connect the bioreactor and adapter tubing set
- Open V1a, and V2a valves (keep V1, and V2 closed)
- SIP through open valves to sterilize the connection
- Close V1a, and V2a valves and open V1, and V2

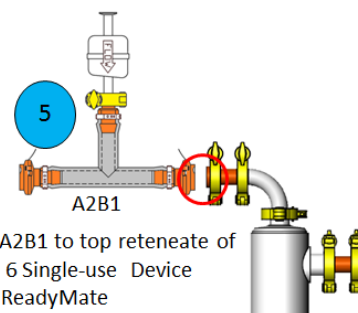

- Connect A2B1 to top reteneate of XCell ATF 6 Single-use Device using GE ReadyMate
- Secure the coupled GE ReadyMate™ connection with a bio clamp.

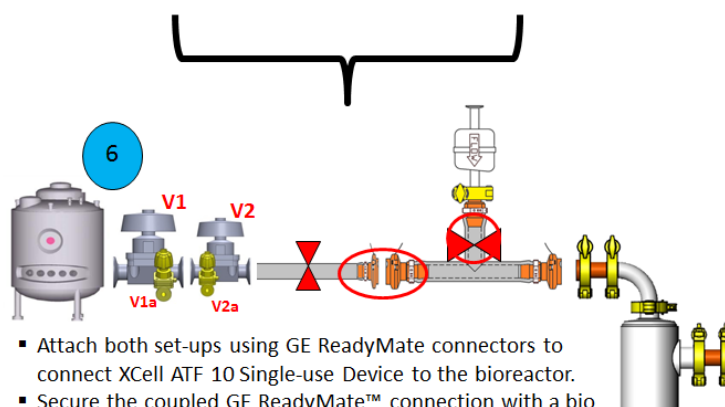

- Attach both set-ups using GE ReadyMate connectors to connect XCell ATF 10 Single-use Device to the bioreactor.
- Secure the coupled GE ReadyMate™ connection with a bio clamp.
- Clamp the tube connected to the vent filter on A2B1

8. Filter Wetting Approaches

8.1 Background

The XCell™ ATF 6 Single-use Device is supplied dry and has not been pre-wetted or flushed. Wetting of the hollow fiber filter in the device is required to ensure robust filter performance. A minimum of 50L of sterile water or cell culture media (recommended) is required to properly wet the filter. The sterile wetting solution should be filled into a 50L Single-use container (bag) fitted with a ReadyMate™ connector. A second, empty 50L bag, also fitted with a ReadyMate™ connector is required for collection of wetting solution that will be collected from the filter permeate side during the filter wetting procedure. These two components are not supplied with the XCell™ ATF 6 Single-use Device. A stand-alone peristaltic pump, capable of accommodating the bag tubing and delivering flow rates of 1- 4 LPM, is also required and not supplied.

Two methods, **off-line wetting** or **on-line wetting**, can be used to wet the hollow fiber filters. Each method is detailed below.

Off-line wetting allows for the filter in the device to be wetted while not connected to a bioreactor and without the use of the XCell™ ATF C410 Controller and the resulting pump action. The off-line wetting configuration and process also allows for pre-use filter integrity testing while maintaining sterility.

The on-line wetting procedure is executed with the device connected to a bioreactor that contains sterile cell culture media (must done prior to inoculation,). This method utilizes the XCell™ ATF C410 Controller to generate the pump action to wet the filter. Additional SU-ATF devices that will be connected to a running bioreactor must undergo off-line wetting.

The off-line wetting procedure is recommended for the following reasons:

- Proper Wetting - Filling the unit from the condition/drain port wets the membrane inside-out, which drives more uniform wetting of the filter and minimizes the formation of air bubbles inside the filter.
- Filter Integrity – This method allows the user to test filter integrity while disconnected from the bioreactor and maintaining sterility. Integrity testing a filter prior to use reduces process risk.
- Sterility Check – Upon completion of the wetting process with cell culture media, the media can be incubated overnight to evaluate the sterility of the device before making a connection to the bioreactor.
- Replacing the Device – In the event that there is need to replace the device during a run, using the offline technique does not require the C410 controller or for the device to be connected to a bioreactor, which may be in use.

8.2 Offline Wetting

8.2.1 Offline Wetting Procedure Instructions

For an overview of the XCell™ ATF 6 Single-use Device off-line wetting process, please refer to the following video: www.repligen.com/xcell_su

- a. Install the device into the stand and attach the tubing sets to set up the XCell™ ATF 6 Single-use Device for the off-line wetting procedure (the stand is not shown in Figure 8.1 for better visualization of the tubing sets)

- i. Set up the device as shown in Figure 8.1 (A2B2 is not required for offline wetting procedure)
 - ii. For an overview of making the required sterile connections, please refer to the GE ReadyMate™ connector installation video:
<https://www.youtube.com/watch?v=A1jl8IPaIOI>
 - iii. Remember to secure a tri-clamp on a coupled GE ReadyMate™ connector to ensure the connection will be integral to the required operating pressures.
 - iv. It is important that the pinch clamps are placed in the proper locations, as shown in Figure 8.1, to ensure effective filter wetting and to prevent the accidental wetting of the vent filters and/unlinked GE ReadyMate™ connectors.
 - v. Prepare a Single-use container (bag) containing 50L wetting solution (WFI or sterile media) and fitted with a GE ReadyMate™ connector.
 - vi. Similarly, prepare another empty Single-use container (bag) fitted with a GE ReadyMate™ connector.
- b. Using the GE ReadyMate™ connectors, connect a 50L bag containing the sterile wetting solution to the condition/drain port and an empty 50L bag to the top permeate port respectively. See Figure 8.1.
 - c. Ensure all tubing clamps are positioned and secured as noted in Figure 8.1. Begin pumping the sterile wetting solution through the condition/drain port at a flow rate of 1 LPM to fill the device with wetting solution.
 - d. Observe carefully, stop the pump when the solution begins to fill the top permeate port, clamp the top permeate port completely such that both vent filter and empty bag segments are closed.
 - e. Restart the pump briefly, when solution begins to fill the elbow on top retentate, stop the pump and clamp the vent filter segment to close the top retentate completely.

Note: Ensure that the wetting solution does not contact the vent filters or the unlinked GE ReadyMate™ connectors at any point during the wetting process. Add a clamp to the top permeate tubing set to isolate (close) the vent filter line, leaving the line to the collection bag open, as shown in Figure 8.2.

- f. Restart the pump at a flow rate of 3 – 4 LPM and continue until the entire 50L of sterile wetting solution has passed through the device and into the permeate collection bag to ensure complete wetting of the filter (see Figure 8.1). It is recommended tilting the ATF until the air above the top permeate port is removed. The flow rate should be adjusted to allow for a minimum wetting time of 15 minutes.

Figure 8.1 Required Initial Set-Up for the Off-Line Wetting of the XCell™ ATF 6 Single-Use Device

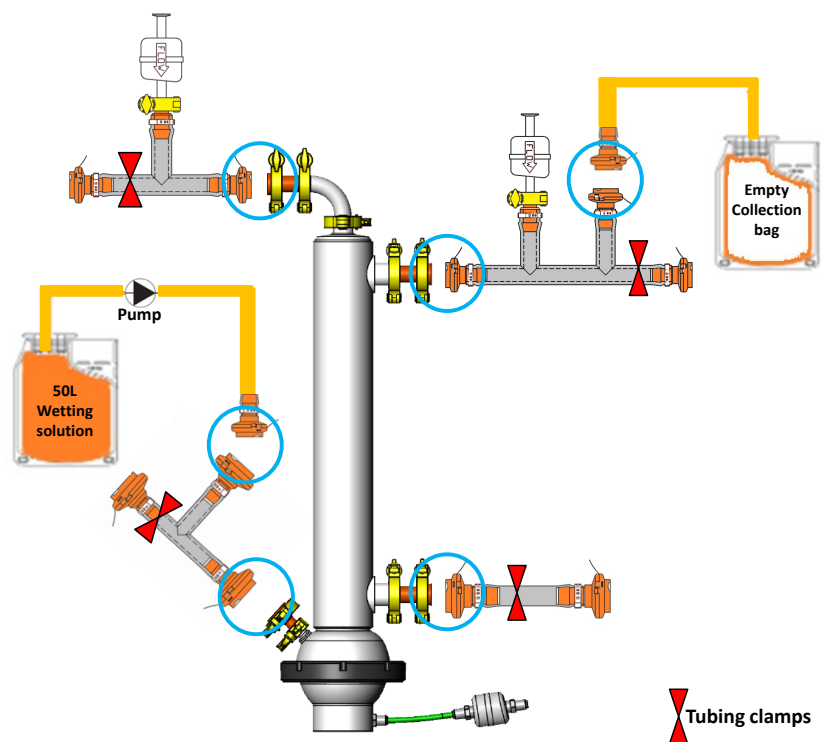
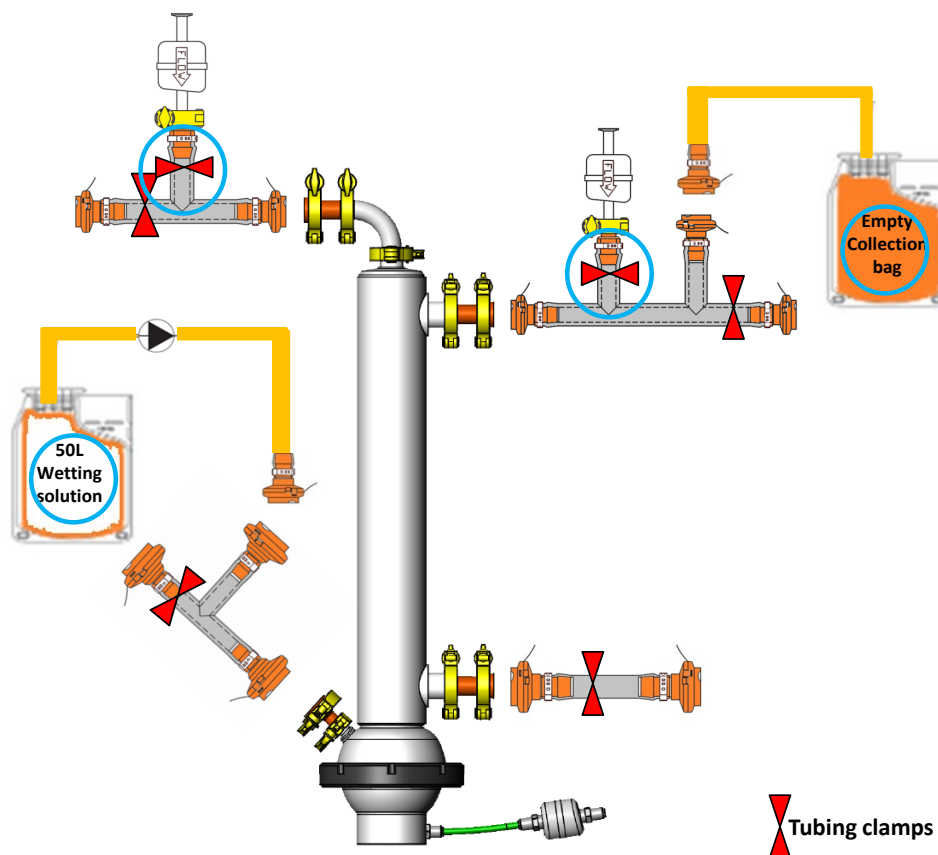

Figure 8.2 Required Final Set-Up for the Off-Line Wetting of the XCell™ ATF 6 Single-Use Device



- g. If a filter integrity test is required, proceed to Step 8.2.2. Otherwise, continue to Step “g” to complete the off-line wetting process.

- h. After wetting, disconnect the wetting solution feed and collection bags from the device in a sterile manner by clamping the respective tubing sets as shown in Figure 8.3.
 - i. If cell culture media was used for wetting, the media collected in the permeate bag can be used to assess the sterility of the device by incubating it in a shake flask
- i. The wetting solution can remain inside the device until the unit is ready to be connected to the bioreactor. Ensure that tubing lines to the vent filters on the top retentate and top permeate tubing sections are clamped.

Figure 8.3 Required Tubing Clamp Configuration for Disconnecting the Feed and Permeate Wetting Bags from the Device

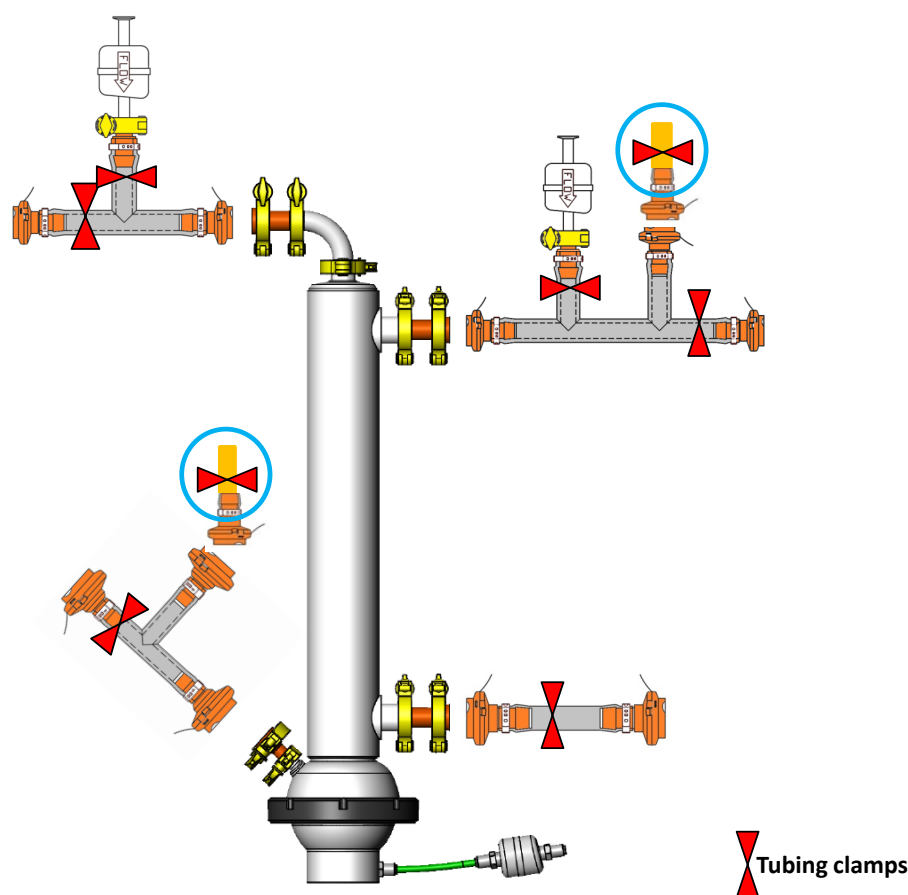

8.2.2 Filter Integrity Evaluation

- a. To test the filter integrity, the wetting step must be deemed complete and the wetting solution must be drained from the device.
- b. Remove the clamps at the vent filters on both the top retentate and top permeate ports.
- c. Close the line to the collection bag with a clamp (see Figure 8.4). Ensure that the condition/drain port clamp is positioned as noted in Figure 8.4.
- d. Start the pump in reverse flow at flow rate of no more than 0.5 LPM in order to drain the wetting solution in the device to the bag at the condition/drain port.

Note: The draining process will not remove all of the solution from the diaphragm pump. The presence of residual wetting solution in the pump will not affect the filter integrity evaluation or the functionality of the device.

- e. After draining the wetting solution, stop the pump and disconnect the bags from the device in a sterile manner by clamping the respective tubing lines.
- f. The device integrity can now be evaluated using a forward air diffusion test by connecting an FIT Tester or a pressure source with an in-line 0-30psi pressure gauge to the vent filter on the top retentate tubing set.
 - i. Ensure that the vent filter on the top permeate tubing is open for diffused air to escape and all remaining pinch clamps are tightened to avoid leaks
- g. Pressurize the unit through the top retentate port vent filter to 10psi and monitor the pressure decay for 5 min as shown in Figure 8.5. The average pressure decay should not exceed 0.3psi/min (diffusion rate should be <30 SCCM/m²) for the unit to pass the filter integrity testing.

Note: To avoid filter drying, it is recommended to clamp the segments leading to vent filters on both permeate and retentate side after FIT evaluation. Other pinch clamps can remain at same locations as shown in Figure 8.5.

Figure 8.4 Required Tubing Clamp Configuration for Draining the Wetting Solution from the Device Prior to Conducting a Filter Integrity Test

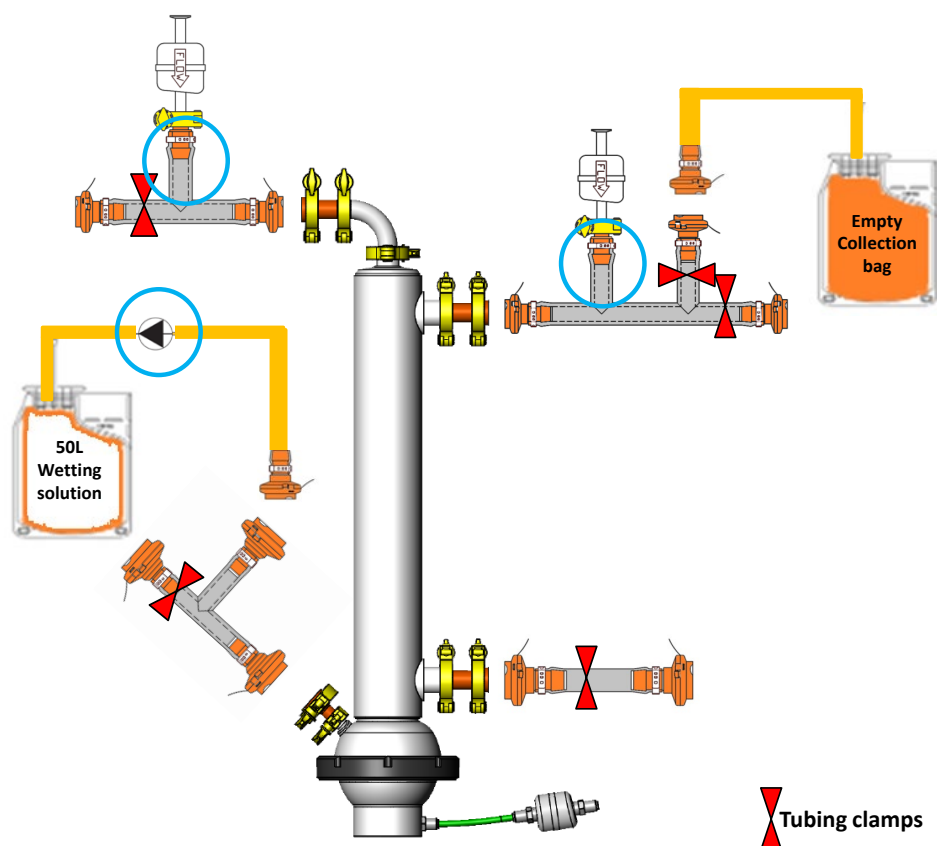

8.2.3 Connection to a Bioreactor

After completing the offline wetting procedure and/or the integrity test, use the A2B2 tubing set to make a connection between bioreactor and the device by using the ReadyMate™ connector or a tube welder as shown in Section 7.

Refer to the XCell™ ATF C410 Controller User Guide for instructions on operating the XCell™ ATF 6 Single-use Device. The operating procedures for the XCell™ ATF 6 Single-use Device and the XCell™ ATF 6 Stainless Steel Device are identical.

Figure 8.5 Required Configuration for Post-Wetting Device Integrity Testing

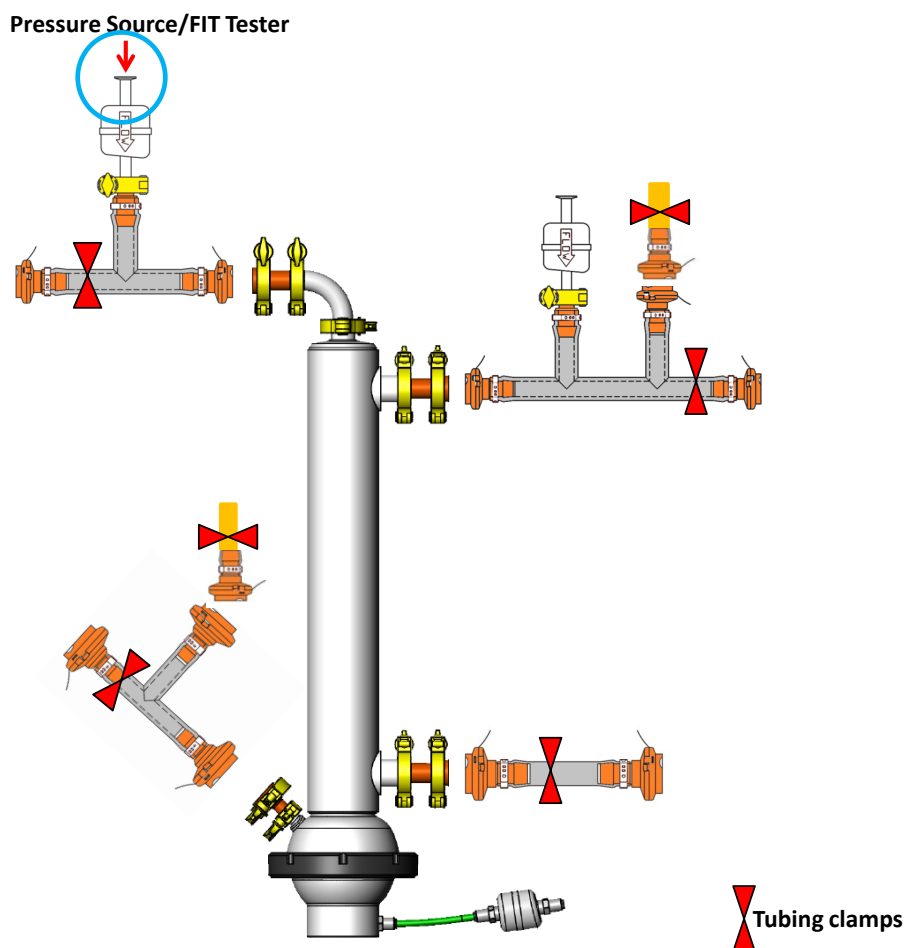

8.3 Online Wetting

The XCell™ ATF 6 Single-use Device filter can also be wetted using an on-line procedure, where the device is wetted after the connection is made to a bioreactor. The XCell™ ATF C410 Controller is used to wet the filter membrane. This method is not amenable to performing a pre-use integrity test.

8.3.1 Online Wetting Procedure

- Prepare the bioreactor as is required for the cell culture process. The bioreactor must contain sterile cell culture media and be cell free (pre-inoculation) for use in wetting. The device wetting should be executed prior to the bioreactor being inoculated.
- Set up the XCell™ ATF 6 Single-use Device by setting the device into the stand (the stand is not shown in Figure 8.6 for better visualization of the tubing pieces).
- Prior to connecting the device to the bioreactor, ensure that all tubing sets and pinch clamps are installed as shown in Figure 8.6.
 - For an overview of the required sterile connections, please refer to the GE ReadyMate™ connector installation video- <https://www.youtube.com/watch?v=A1jl8IPaIOI>.

- ii. Remember to install a tri-clamp on a linked GE ReadyMate™ connector to ensure proper connection and integrity to the required operating pressures.
- iii. It is important that the pinch clamps are placed in proper locations, as shown in Figure 8.6, to prevent accidental wetting of vent filters and un-linked GE ReadyMate™ connectors.
- d. After installation of the pinch clamps, connect the device to the bioreactor using the A2B2 tubing set, see Figure 8.6.
- e. Connect the C410 Controller to the device via the A2C connection. Refer to the XCell™ ATF C410 User Guide for additional instruction on the operation of the ATF.
- f. Prepare an empty 50L Single-use container (bag) fitted with a GE ReadyMate™ connector.
- g. Using the GE ReadyMate™ connect the empty 50L bag to the tubing segment attached to the top permeate port, as shown in the Figure 8.6.

Figure 8.6 Required Initial (Set-Up) Configuration for the Online Wetting of the Device

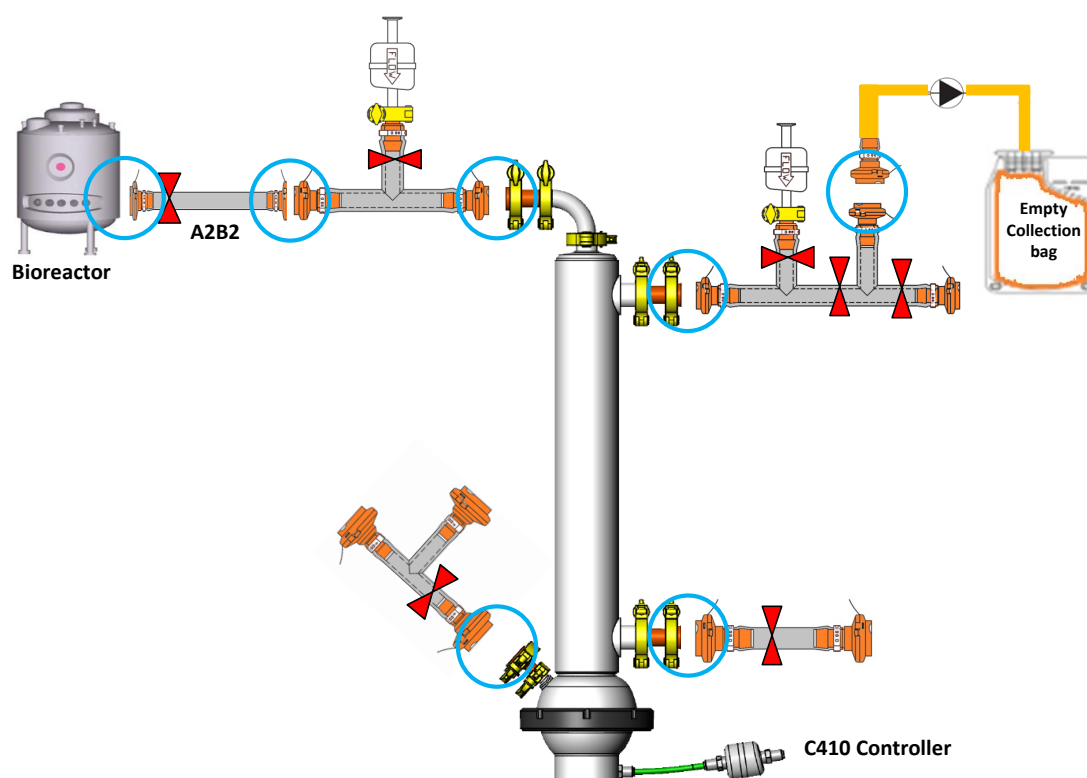

- h. Remove the clamp on the top retentate tubing segment such that the line between the bioreactor and the device is open.
 - i. Ensure that tubing to the vent filter on the top retentate is clamped.
 - ii.

Note: Bioreactor head pressure may force the media into the device without the ATF action.

- i. Start the XCell™ ATF pump from the C410 controller at a flow rate of 17.2 LPM (P & E) and let it run for 5 minutes till all air bubbles disappear.
- j. After equilibration, remove the clamp to the empty 50L bag on the top permeate port and immediately start the top permeate pump at a flow rate 3-4 LPM.
- k. Collect at least 50L of wetting solution in the top permeate collection bag, see Figure 8.7.
 - i. It is recommended to perform this process for more than 15 minutes to properly wet the hollow fiber filter.

- I. After completion of the on-line wetting process, stop the permeate pump and then the XCell™ ATF pump. Clamp the A2B2 tubing line and disconnect the collection bag from the top permeate port in a sterile manner by clamping the tube as shown in Figure 8.8.
 - i. The media from the collection bag can be used to determine the sterility of the wetted XCell™ ATF 6 Single-use Device.
- m. The remaining solution inside the device can be left as-is, until the bioreactor is ready for the perfusion process.
- n. Both the retentate and permeate vent filters need to be closed before starting the perfusion process.

Figure 8.7 Required Working Configuration for Online Wetting of the Device

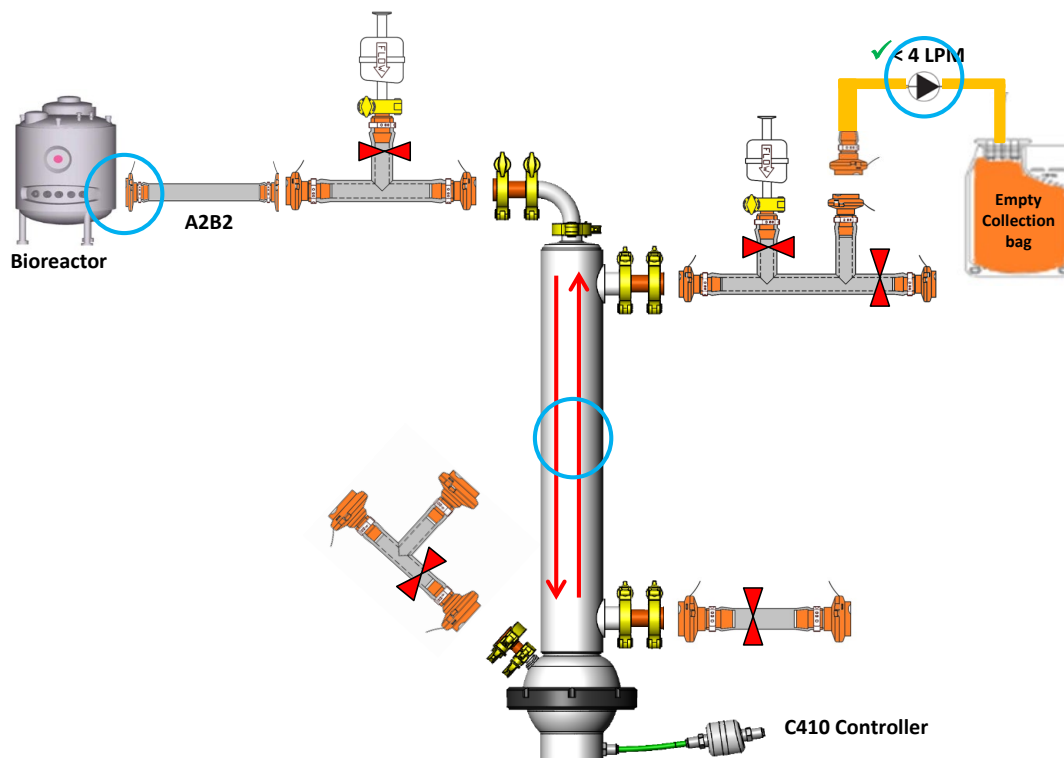
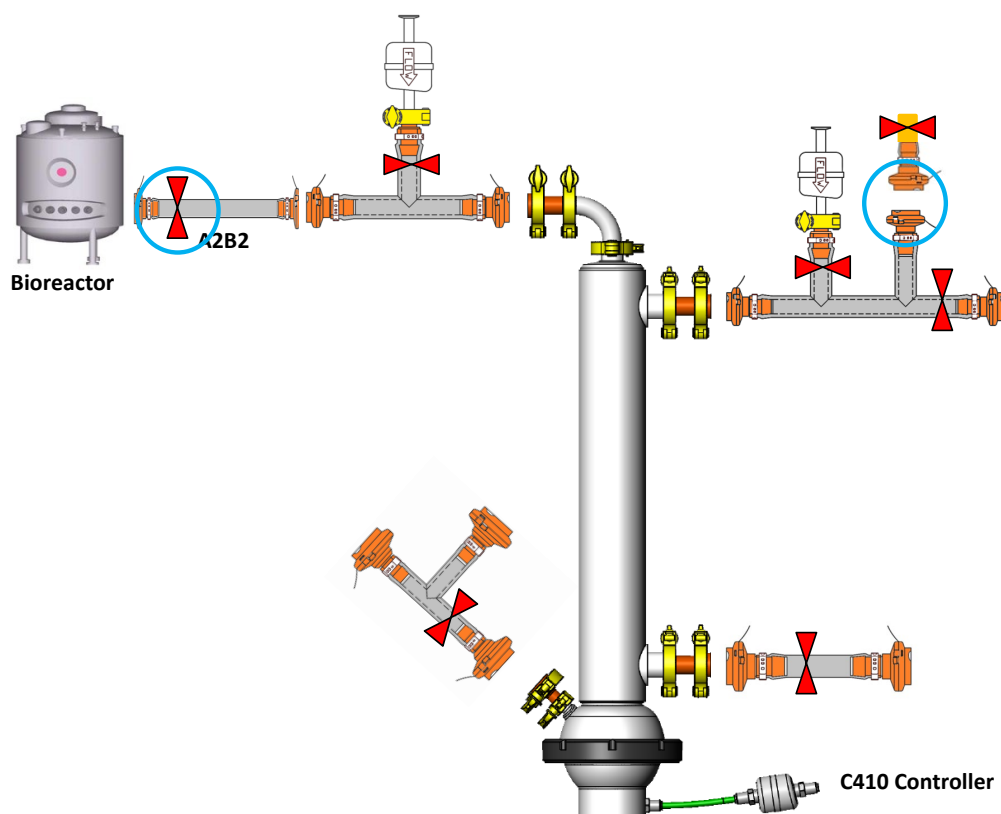

Figure 8.8 Configuration for Disconnecting the Collection Bag from the Device



9. Post-use Instructions

After completion of a cell culture process using the XCell™ ATF 6 Single-use Device, use the following instructions to discard the device.

- Stop the permeate pump and disconnect the harvest bag in a sterile manner.
- Stop the XCell™ C410 controller to stop the pump action and disconnect the XCell™ ATF 6 Single-use Device A2C line from the controller.
- Clamp both the A2B2 and top permeate tubing lines using tubing clamps.
- Prepare an empty bag or a container (>5 L) fitted with a ReadyMate™ connector. Using the ReadyMate™ connector, connect the empty bag/container to the condition/drain port.
- Remove the clamps at the vent filters on both the top retentate and top permeate ports. Detach the clamp at condition/drain port to drain the culture into the empty bag.
- Begin the draining of cell culture solution through the condition/drain port at a flow rate of 1 LPM to the bag/container.

Note: The device may need to be tilted in order to drain the cell culture solution from the diaphragm pump.

- The pump and disconnect the bag from the device. Now the device is ready to be discarded by following proper waste disposable codes.

10. Frequently Asked Questions

1. What do I do if a vent filter gets wet during the wetting process?

Vent filters are made of hydrophobic membrane; wetting solution getting in contact with vent filters for short duration (< 15 minutes) does not impact the integrity and sterility of vent filter and XCell™ ATF 6 Single-use Device. We recommend purging the vent filter to remove the residual solution.

2. What do I do if a leak is detected during the off-line wetting procedure?

Each individual device is pressure tested at 25psi to ensure the integrity of the entire assembly. However, if a leak is detected during wetting process, immediately stop the peristaltic pump and identify the location of the leak. Please ensure that the GE ReadyMate™ DACs and tubing clamps are appropriately installed at proper locations. Clamping wrong tubing sets during wetting procedure pressurizes the device and leads to leakage. If no faults were found in setup, please contact a local Sales Manager or customer service for further support.

3. How do I ensure the sterility of an XCell™ ATF 6 Single-use Device?

The wetting solution collected from off-line wetting procedure can be incubated in a shake flask at 37°C for 24 hours to assess the sterility of a device.

4. How long can the XCell™ ATF 6 Single-use Device be stored in a wet condition before connecting to a bioreactor?

After completing the wetting procedure, the tubing segment leading to the vent filters on the A2B1 and the top permeate tubing segments must be closed using tubing clamps to avoid filter drying. The device can be stored in a wet condition for one week before installing the device for cell culture processing.

5. What do I do if the device fails pre-use integrity testing?

Please ensure that the tubing clamps on the retentate side are properly installed. Generally, if the filter integrity is failed by small percentage (acceptance criteria: 30 SCCM/m²), we recommend to wet the filter again using the same procedure. If a gross leak is detected during integrity, please contact a local Sales Manager or customer service for further support.

6. Does the XCell™ ATF 6 Single-use Device perform similarly to XCell™ ATF 6 Stainless Steel Device?

Yes, the filter used in the XCell™ ATF 6 Single-use Device is same as the one which is being used in the XCell™ ATF 6 stainless steel systems. In addition, the single-use device is operated using the same XCell™ C410 controller as stainless steel without modifying any parameters and the pumps between the stainless steel and Single-use equipment is identical. For comparison purposes, perfusion cultures were also performed on single-use and stainless steel devices. Results suggest that there is no difference in cell growth, viability, achievable cell density and protein production profiles between two devices.

11. Index

Connection Kit.....	3, 4, 9, 10	Online Wetting.....	3, 4, 20, 21, 22
GE ReadyMate™..	6, 7, 9, 11, 16, 20, 21, 24	Tubing Set	7, 9, 11, 16, 19, 21
Hollow Fiber Filter.....	7, 15, 22	Wetting Procedure	3, 15, 20
Offline Wetting	3, 15		